

INSPECTION

1. INSPECT FRONT WIPER AND WASHER SWITCH CONTINUITY

Switch position	Tester connection	Specified condition
OFF	7 – 16	Continuity
MIST	7 – 17	Continuity
INT	7 – 16	Continuity
LO	7 – 17	Continuity
HI	8 – 17	Continuity
Washer ON	2 – 11	Continuity

If continuity is not as specified, replace the switch.

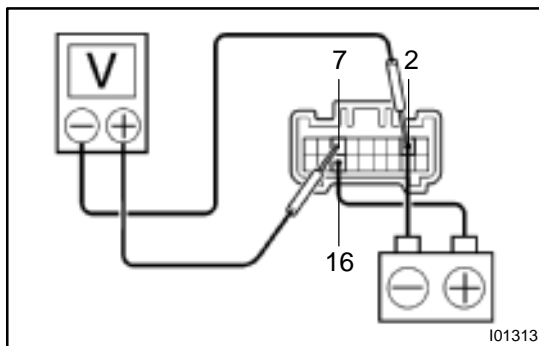

2. INSPECT WIPER INTERMITTENT OPERATION

- Turn the wiper switch to INT position.
- Turn the intermittent time control switch to FAST position.
- Connect the positive (+) lead from the battery to terminal 16 and the negative (-) lead to terminal 2.
- Connect the positive (+) lead from the voltmeter to terminal 7 and the negative (-) lead to terminal 2, check that the meter needle indicates battery positive voltage.

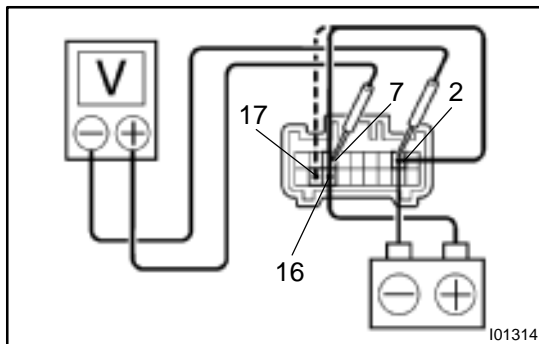

- After connecting terminal 16 to terminal 17, connect to terminal 2 to terminal 17, check the voltage rises from 0 volts to battery positive voltage with in the times, as shown in the table.

INT time control switch position	Voltage
FAST	Approx. 1 – 3 sec.
SLOW	Approx. 10 – 15 sec.

If operation is not as specified, replace the wiper and washer switch.

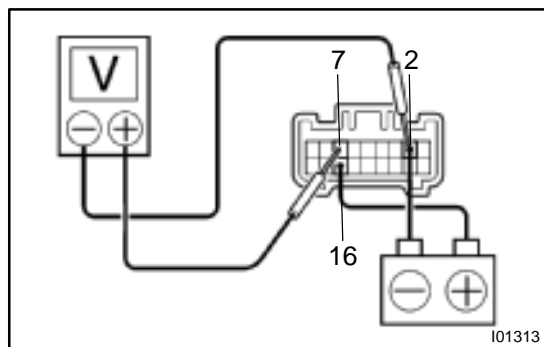

3. INSPECT FRONT WASHER LINKED OPERATION

- Connect the positive (+) lead from the battery to terminal 16 and the negative (-) lead to terminal 2.
- Connect the positive (+) lead from the voltmeter to terminal 7 and the negative (-) lead to terminal 2.
- Push in the washer switch, and check that the voltage changes, as shown in the table.

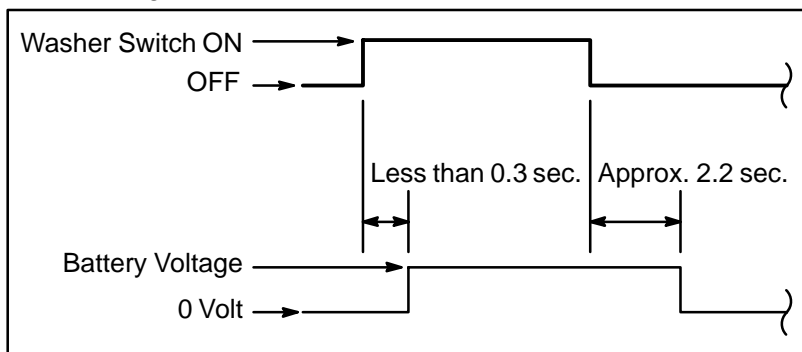

If operation is not as specified, replace the wiper and washer switch.

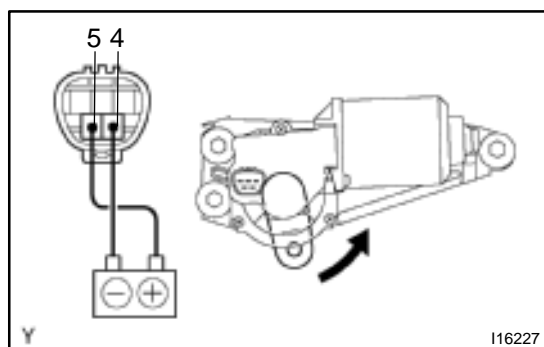

4. Low speed:

INSPECT FRONT WIPER MOTOR OPERATION

Connect the positive (+) lead from the battery to terminal 5 and the negative (-) lead to terminal 4, check that the motor operates at low speed.

If operation is not as specified, replace the motor.

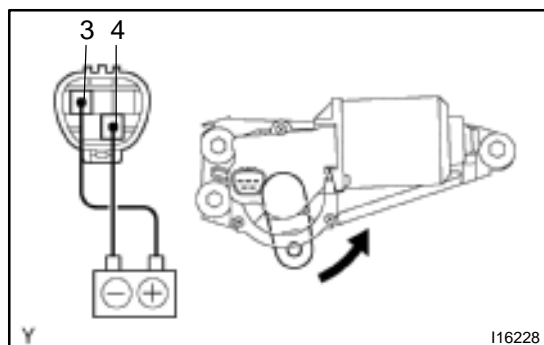

5. High speed:

INSPECT FRONT WIPER MOTOR OPERATION

Connect the positive (+) lead from the battery to terminal 3 and the negative (-) lead to terminal 4, check that the motor operates at high speed.

If operation is not as specified, replace the motor.

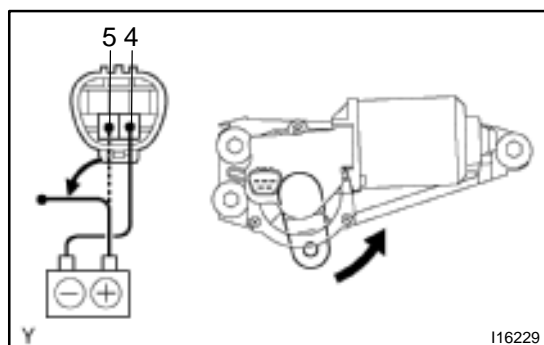

6. Stopping at stop position:

INSPECT FRONT WIPER MOTOR OPERATION

- Operate the motor at low speed and stop the motor operation anywhere except at the stop position by disconnecting positive (+) lead from terminal 5.

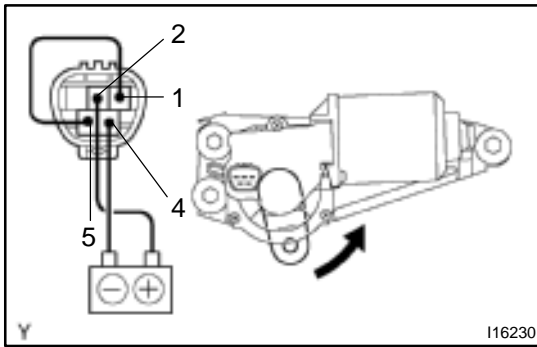

- (b) Connect terminals 1 and 5.
 (c) Connect the positive (+) lead from the battery to terminal 2 and negative (-) lead to terminal 4, check that the motor stops running at the stop position after the motor operates again.

If operation is not as specified, replace the motor.

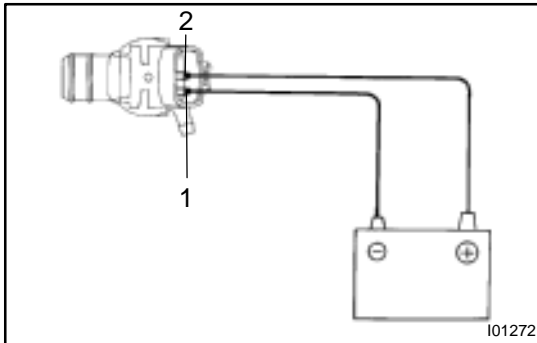

7. INSPECT WASHER MOTOR OPERATION

Connect the positive (+) lead from the battery to terminal 2 and the negative (-) lead to terminal 1, check that the motor operates.

NOTICE:

These tests must be performed quickly (within 20 seconds) to prevent the coil from burning out.

If operation is not as specified, replace the motor.